



AGRI Solar

**Electric Fence
Energizer**

Instruction Manual



Powered by
NEMTEK
Electric Fencing Products



Introduction & Company Profile _____	3
Guarantee _____	4
Strainrite Fencing Systems _____	5
Symbol Key _____	6
Energizer Details & Mounting _____	7
Energizer Features _____	8
Product Specifications _____	9
Operating the Energizer _____	10
Using the Nemtek Tag _____	10
Installation Notes _____	12
Appendix _____	13 - 16
Document Revision History _____	17

INTRODUCTION

Thank you for choosing our product! NEMTEK Electric Fence Energizers are designed and manufactured to provide many years of reliable use, if installed and maintained correctly. The guidelines provided in this manual will assist you with the basic operation and maintenance of your energizer.

Currently this energizer is designed and manufactured in South Africa for the South African and international markets. More information on our products and general information are available on our web site at: <http://www.nemtek.com>.

COMPANY PROFILE

The NEMTEK Group of Companies manufacture and distribute intelligent electronic agricultural fencing systems, security and perimeter control systems and have been involved in the security industry since 1990.

We have our own research and development team, designing and manufacturing a full range of globally competitive electric fence energizers and related products.

NEMTEK is continually updating its products according to South African and international standards in order to ensure the highest quality products and continuous customer satisfaction.

Electric fencing can be lethal. Avoid head contact with the fence. When installing please take careful note of the options available for current limiting resistors, the programmable output energy levels as well as the low-voltage operation of the energizer.

GUARANTEE

This energizer, manufactured by IO Tech Manufacturing (Pty) Ltd, is guaranteed for a period of two years from date of sale against defects due to faulty workmanship or materials.

IO Tech Manufacturing (Pty) Ltd will, at its discretion, either repair or replace a product that proves to be defective.

IO Tech Manufacturing (Pty) Ltd guarantees that the product, when properly installed and used in line with the specification as determined by IO Tech Manufacturing (Pty) Ltd from time to time, will execute its function of generating a suitable potential. IO Tech Manufacturing (Pty) Ltd does not guarantee that the operation of the product will be uninterrupted and totally error free. Faulty units must be returned to one of the Nemtek Group outlets. The buyer shall pay all shipping and other charges for the return of the product to Nemtek or Nemtek Security Warehouse.

LIMITATION OF GUARANTEE

The guarantee does not apply to defects resulting from acts of God, modifications made by the buyer or any third party, misuse, neglect, abuse, accident and mishandling.

EXCLUSIVE REMEDIES

The remedies provided herein are IO Tech Manufacturing (Pty) Ltd's sole liability and the buyer's sole and exclusive remedies for breach of guarantee. IO Tech Manufacturing (Pty) Ltd shall not be liable for any special, incidental, consequential, direct or indirect damages, whether based on contract, tort, or any other legal theory. The foregoing guarantee is in lieu of any and all other guarantees, whether expressed, implied, or statutory, including but not limited to warranties of merchantability and suitability for a particular purpose.

Head Office

Tel: +64 4 524 9027

Email: sales@strainrite.co.nz

Address

81 Montgomery Crescent
Clouston Park, Upper Hutt 5018
Wellington
New Zealand

Export

export@strainrite.co.nz

POWERED BY NEMTEK

Strainrite is proud to bring to the market an energizer range powered by Nemtek. A world leading manufacturer of agriculture and security energizers. Nemtek incorporates the Strainrite philosophy of delivering quality, tested and proven agricultural equipment to the market, with innovative expertise. Strainrite Energizers should be your first choice animal management solution.

MORE ABOUT STRAINRITE

Strainrite Fencing Systems are a leading agricultural equipment manufacturer, with a history that dates back to the early 1970s. Renowned for their innovation, the company designs and builds an extensive range of fencing tools and equipment.

Located in New Zealand's capital city, Strainrite Fencing Systems are renowned for quality fencing products built to the requirements of the farming sector. With a focus on product development and innovation, Strainrite Fencing Systems listen to the market and deliver market-leading fencing products that withstand the tough and demanding farming elements.

Strainrite know farming. Their fencing tools and equipment are designed by farmers, for farmers.

They understand their customer needs, and continually refine their products to ensure they deliver the best results.

For more info visit www.strainrite.co.nz

Symbols on the energizer body



Represents the Nemtek Tag target



Represents fence earth connection, terminal



Represents fence live connection, terminal

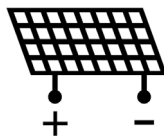

Represents power from solar panel

BACK VIEW

Mounting Bracket
(various options - see below)

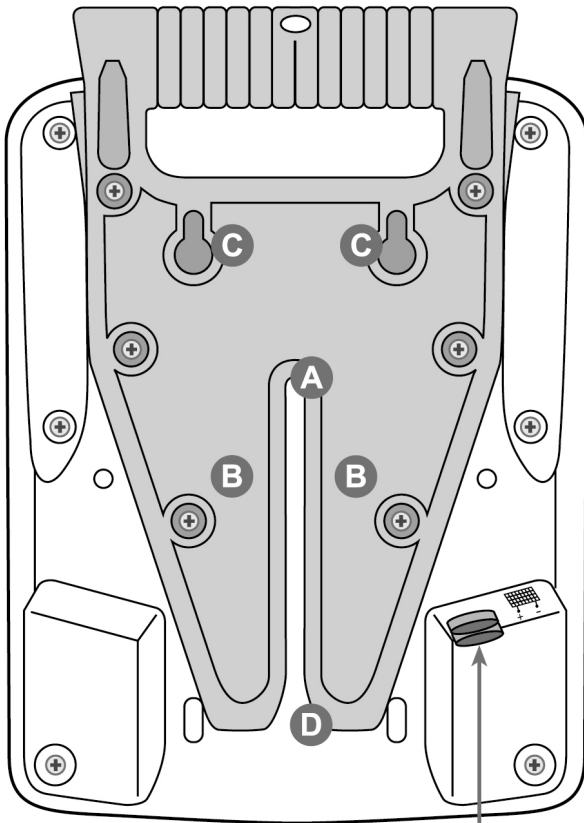

Solar Connections

FRONT VIEW

'SOLAR' Solar power status
'BATTERY' Battery Status Indication
'ENERGIZER' Pulse Rate & Power Level Indication

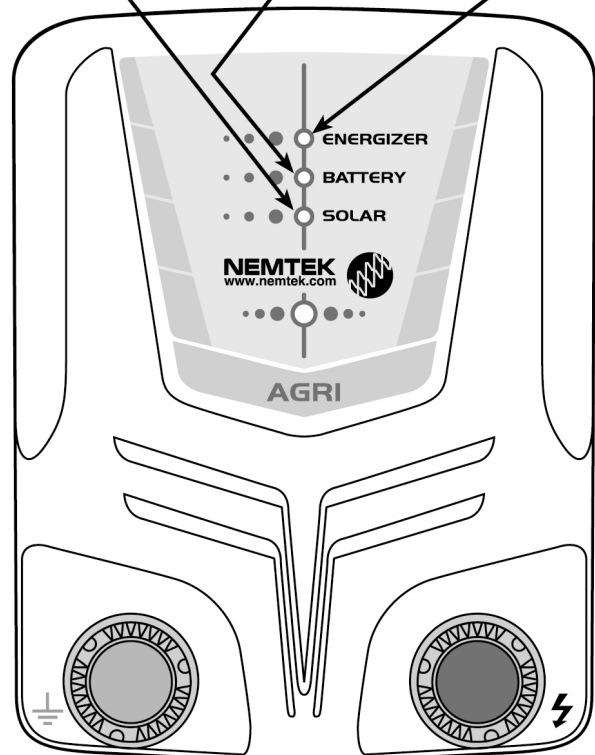

Fence Ground

Fence High Voltage

MOUNTING BRACKET OPTIONS

Note: Slot on top of bracket is for solar panel mounting

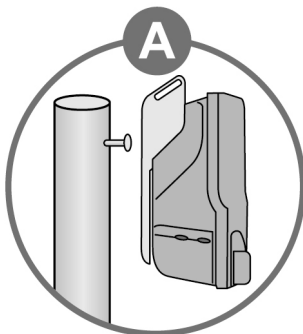

Hanging on a nail hammered into a wooden post (using the slot in the bracket)

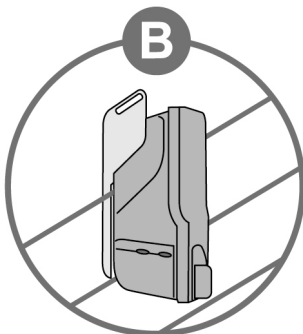

Hanging on a wire fence using the 'bunny teeth' sections of the mounting bracket

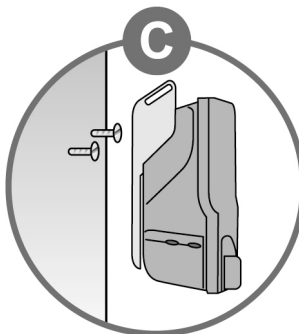

Wall mounted with 2x screws using the screw-mount slots on the mounting bracket

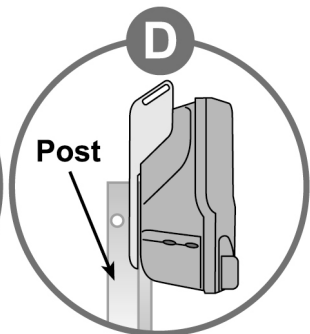

Mounted on a metal fence post using the specially designed slot in the bracket

- Robust weather resistant housing
- Power status indication (BATTERY)
green = charged, red = low, yellow = in-between
- Pulse rate and power level indicator (ENERGIZER on the unit)
green = high power, red = low power
- Solar regulator status
green = battery charging, unlit LED = battery discharging,
red = battery not connected/failure
- Day/night sensor
- Internal buzzer beeps when using Nemtek Tag
- Internal solar regulator
- Internal, long-life, eco-friendly battery

Nemtek Tag

- Used to toggle the energizer active state (on/off)
- Used to toggle the energizer between high and low power modes

Agri Solar

	1	3	5	8
Battery	12.8V	12.8V	12.8V	12.8V
Power consumption	111mW	265mW	420mW	625mW
Output energy into 500ohm	0.1J	0.25J	0.45J	0.66J
Maximum fence voltage	10kV	10kV	10kV	10kV
Environmental rating	IP65	IP65	IP65	IP65
Maximum fence length (optimal fence*)	1km	3km	5km	8km
Recommended PV panel	5W	5W	10W	10W

(Open circuit voltage (max) = 23V)

Note: All specifications and recommendations based on 1.5 second pulse rate

*The distances that can be powered are a guideline only and apply to the optimal fence conditions. Factors such as resistance, diameter and type of fence wire, the fence installation, proximity of live fence wires to other earth wires, the amount of vegetation touching the fence and earthing of the fence system will influence the distance that can be powered.

Present the Nemtek Tag (Supplied with the energizer)

Operating the energizer is straightforward. Once the energizer is turned on, it will pulse the fence once per 1.5 seconds. The pulse rate & power indicator (ENERGIZER) should flash once with each fence pulse.

The (ENERGIZER) indicator flashes green to indicate high power mode or red to indicate low power mode. The power status indicator (BATTERY) glows green if the battery is above 50% capacity, glows yellow when the battery capacity falls below 50% and glows red when the battery capacity is below 5%.

The energizer disconnects the battery when the battery becomes discharged, and will reconnect the battery automatically when solar power is available again. Solar regulator status (SOLAR) is green when the battery is charging, unlit when the battery is discharging and red when the battery is not connected.

If the energizer is not actively pulsing, it will automatically disconnect the battery after a short period of time and can be stored away in this state. The battery will automatically get reconnected when solar power is available or the Nemtek tag is presented to the energizer.

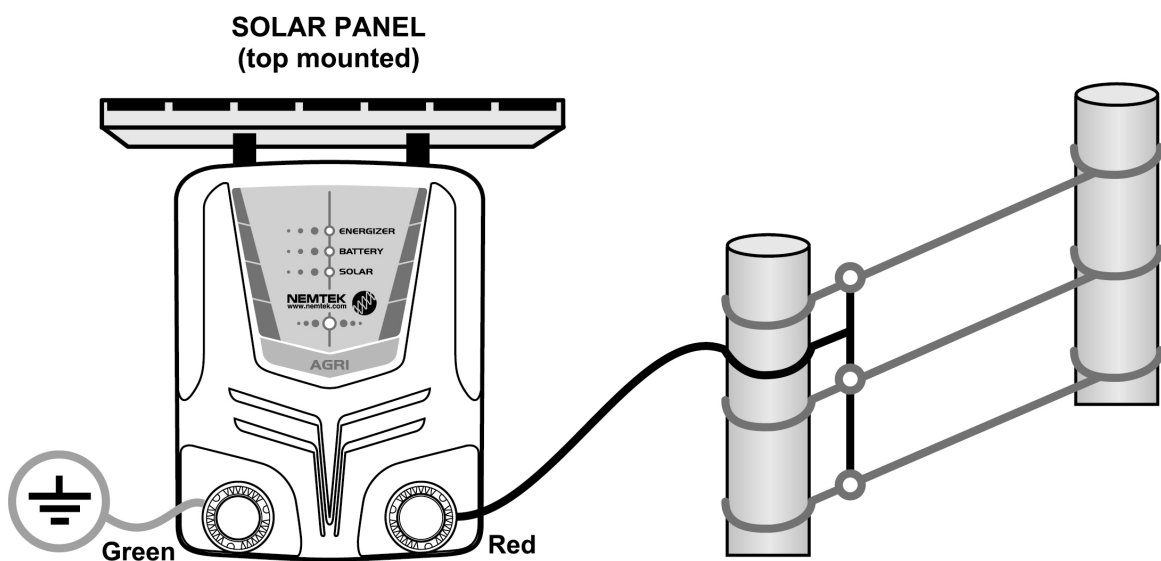

Energizer

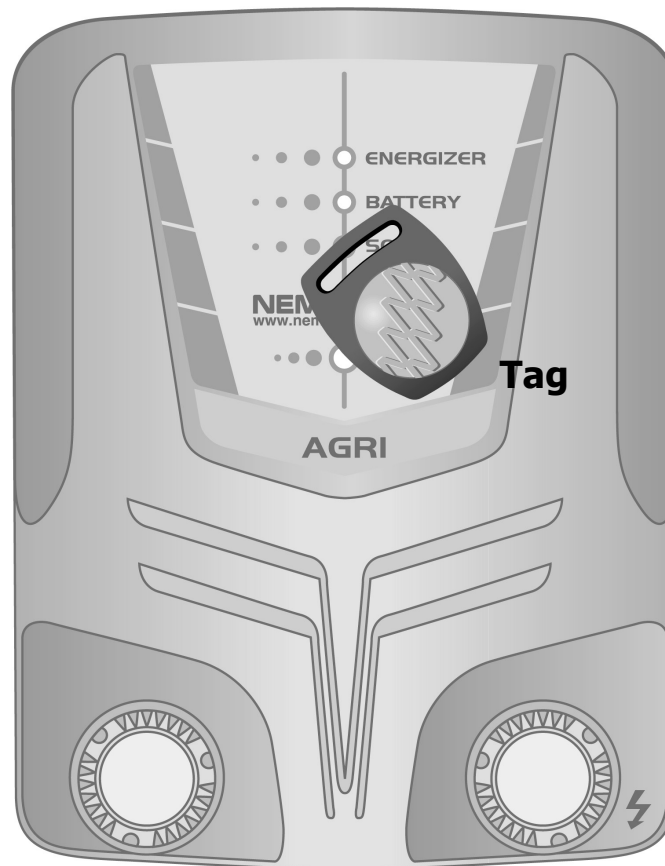

The Nemtek tag is used to toggle the energizer on/off or to toggle the energizer between the low or high power operating state. Hold the tag over the Nemtek logo on the front of the energizer and the energizer will emit a short beep upon detecting the tag.

To toggle the energizer on or off, remove the tag after this first beep and the energizer will emit a further beep when turning on, or a double beep when turning off.

To toggle the low/high power operating state of the energizer, keep presenting the tag after the initial detection beep. After about 1.5 second has passed, a long beep will be emitted. The tone of this long beep will be low if the energizer has switched to low power mode or high if the energizer has switched to high power mode. Once active, the (ENERGIZER) LED will pulse green if the energizer is in high power mode or red if the energizer is in low power mode.

In order to extend the battery operating life of the energizer, The BATTERY and SOLAR indicators will only remain active for 1 minute each time the Nemtek Tag is presented to the energizer. The indicators do however remain active, should solar power be present and the energizer is not actively pulsing the fence.

- Keep the fence separate from the battery wiring.
- Do not try and modify the energizer. Any unauthorized modifications will null and void the warranty and possibly render the unit illegal.
- Use HT (high voltage) wire between the fence and energizer, including the earth wire. Never run these wires in the same conduit or through the same hole as the low voltage wiring.
- Always use ferrules or line clamps to connect two high voltage wires together. Avoid using dissimilar materials for connections, like copper on steel.
- The fence must be earthed properly with three earth electrodes close to the energizer. The distance between the fence earth electrode and any other earth systems shall not be less than 2m for a security fence installation (typically a suburban property installation), and 10m for an agricultural fence installation (typically a rural property installation).
- Refer to the applicable laws concerning the installation of electric fences in your area.

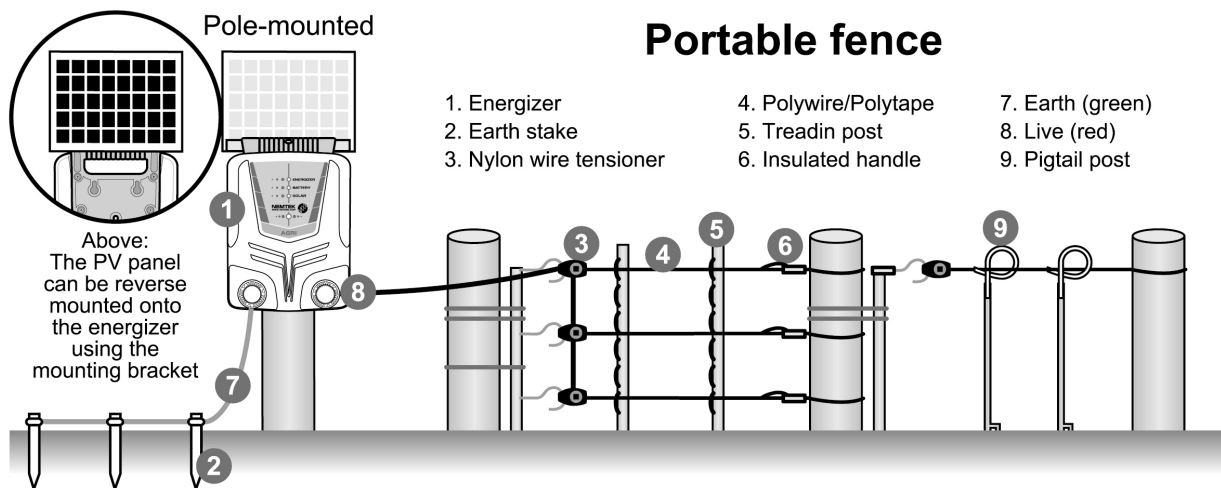
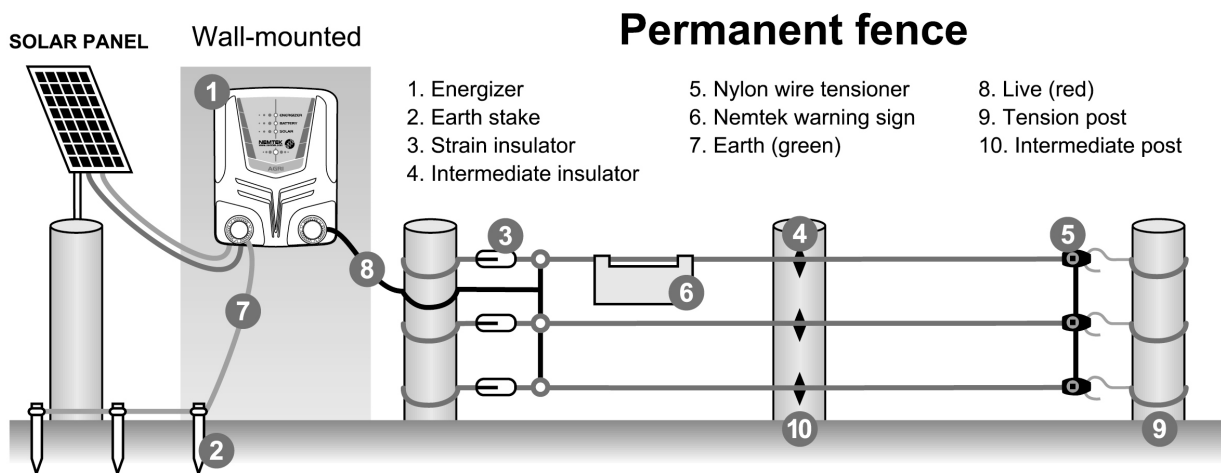

Basic definitions

- **Energizer:**
An appliance intended to periodically deliver voltage impulses to a fence connected to it.
- **Electric Fence:**
A barrier which includes one or more electric conductors, insulated from earth, to which electric pulses are applied by an energizer
- **Connecting Lead:**
An electric conductor, used to connect the energizer to the electric fence or the earth electrode
- **Electric animal fence:**
An electric fence used to contain animals within or exclude animals from a particular area
- **Public Access Area:**
Any area where persons are protected from inadvertent contact with pulsed conductors by a physical barrier
- **Pulsed Conductors:**
Conductors which are subjected to high voltage pulses by the energizer
- **Earth electrode:**
Metal structure that is driven into the ground near an energizer and connected electrically to the fence earth terminal of the energizer, and that is independent of other earthing arrangements.

General requirements for electric fences

Electric fences shall be installed and operated so that they cause no electrical hazard to persons, animals or their surroundings.

Electric fence constructions which are likely to lead to the entanglement of animals or persons shall be avoided.

An electric fence shall not be supplied from two different energizers or from independent fence circuits of the same energizer.

For any two different electric fences, each supplied from a different energizer with independent timing, the distance between the wires of the two electric fences shall be at least 2.5m. If this gap is to be closed, this shall be affected by means of electrically nonconductive material or an isolated metal barrier.

Barbed wire or razor wire shall not be electrified by an energizer.

Electric fences and their ancillary equipment shall be installed, operated and maintained in a manner that minimizes danger to persons, and reduces the risk of persons receiving an electric shock unless they attempt to penetrate the physical barrier, or are in a secure area without authority. Exposed conductive parts of the physical barrier shall be effectively earthed.

A spacing of 2.5m shall be maintained between non insulated electric fence conductors or non insulated connecting leads supplied from different energizers. This spacing may be less where conductors or connecting leads are covered by insulating sleeving, or consist of insulated cables, rated to at least 10kV.

This requirement need not apply where the separately energized conductors are separated by a physical barrier, which does not have any openings greater than 50mm.

A vertical separation of not less than 2m shall be maintained between pulsed conductors fed from different energizers.

Ensure that all ancillary equipment connected to the electric fence circuit provides a degree of isolation between the fence circuit and the supply mains equivalent to that provided by the energizer. Protection from the weather shall be provided to the ancillary equipment unless this equipment is certified by the manufacturer as being suitable for use outdoors, and is of a type with a minimum degree of protection IPx4.

Connecting leads that are run inside buildings shall be effectively insulated from the earthed structural parts of the building. This may be achieved by using insulated high voltage cable.

Connecting leads that are run underground shall be run in a conduit of insulating material or else insulated high voltage cable shall be used. Care shall be taken to avoid damage to the connecting leads due to external factors.

Connecting leads shall not be installed in the same conduit as the mains supply wiring, communication cables or data cables.

Connecting leads and electric fence wires shall not cross above overhead power or communication lines.

Any part of an electric fence which is installed along a public road or pathway shall be identified at frequent intervals by prominently placed warning signs securely fastened to the fence posts or firmly clamped to the fence wires. The size of the warning signs shall be at least 100mm x 200mm. The background colour of both sides of the warning plate shall be yellow. The inscription on the plate shall be in black.

The warning sign shall typically appear as depicted in the figure below. The inscription shall be indelible, inscribed on both sides of the warning plate, and have a height of at least 25mm.



Warning signs shall be placed at;

- each gate
- each access point
- intervals not exceeding 10m
- adjacent to each sign relating to chemical hazards for the information of emergency services.

Gates in electric fences shall be capable of being opened without the person receiving an electric shock.

Mains supply wiring shall not be installed in the same conduit as signaling leads associated with the electric fence installation.

Where an electric fence passes below bare power line conductors, the highest metallic element shall be effectively earthed for a distance of not less than 5m on either side of the crossing point.

Crossings with overhead power lines shall be avoided wherever possible. If such a crossing cannot be avoided, it shall be made underneath the power line and as nearly as possible at right angles to it.

If connecting leads and electric fence wires are installed near an overhead power line, the clearances shall not be less than those shown in the table below.

Power Line Voltage	Clearance
Equal or less than 1kV	3 meter
Greater than 1kV, but equal or less than 33kV	4 meter
Greater than 33kV	8 meter

If connecting leads and electric fence wires are installed near an overhead power line, their height above the ground shall not exceed 3m.

This height applies either side of the orthogonal projection of the outermost conductors of the power line on the ground surface, for a distance of:

- 2m for power lines operating at a nominal voltage not exceeding 1kV
- 15m for power lines operating at a nominal voltage exceeding 1kV

Warning

There are no serviceable parts inside the energizer.

This appliance is not intended for use by persons (including children) with reduced physical, sensory or mental capabilities or lack of experience and knowledge, unless they are supervised or have been given instruction on the correct use of the appliance by a competent and responsible person.

Non-rechargeable batteries must not be connected to this device while the energizer is powered from an alternate power source.



Connection of this energizer to mains powered equipment, including battery chargers, is prohibited.

After a prolonged period of service, the internal LiFePO₄ battery pack will drop in capacity. Once the standby time of the energizer is no longer sufficient, return the unit to an authorised Nemtek dealer for replacement of the battery.

Please dispose of this energizer in an eco-friendly way at the end of its life.

Rev 1.0, 31 March 2016